

**ELEVATION ON PANELS**  
(Scale 1:20)

**SECTION 06**  
(Scale 1:20)

1060 DIMENSIONS MARKED THIS ARE TO BE MEASURED ON SITE AND INCORPORATED INTO THE FABRICATION DETAILING

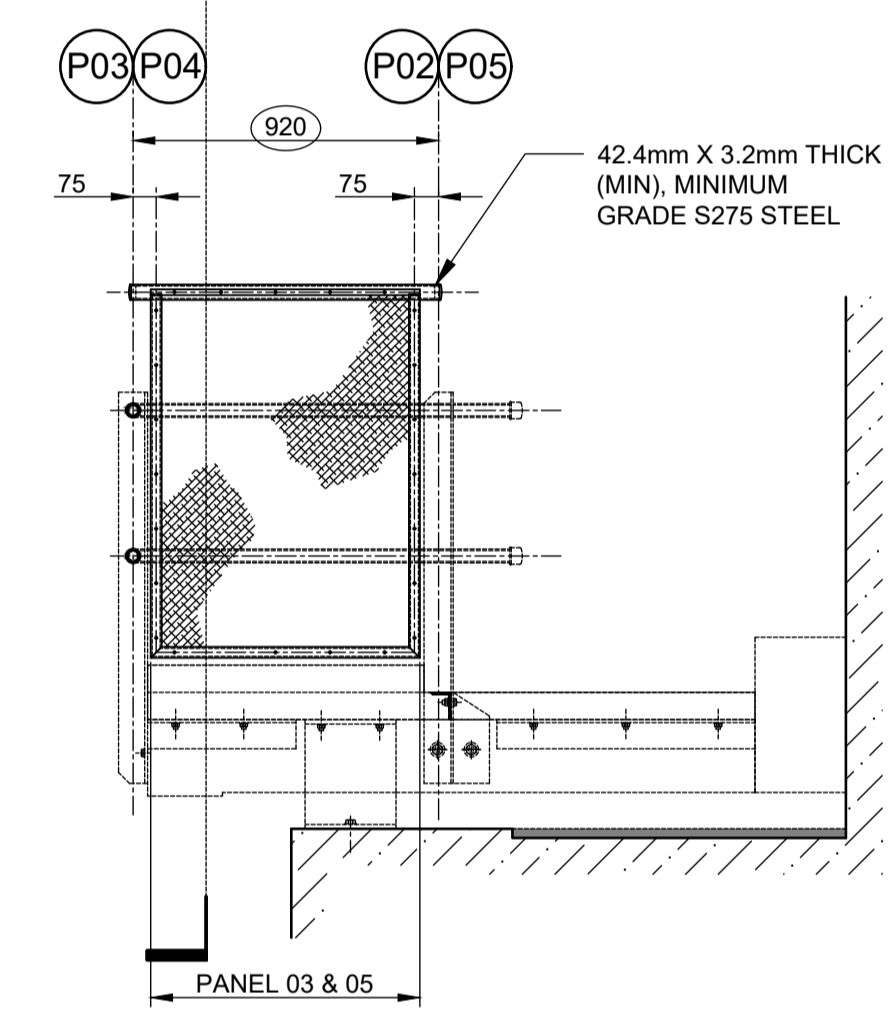

**ELEVATION - PLATFORM SIDE**  
(Scale 1:20)

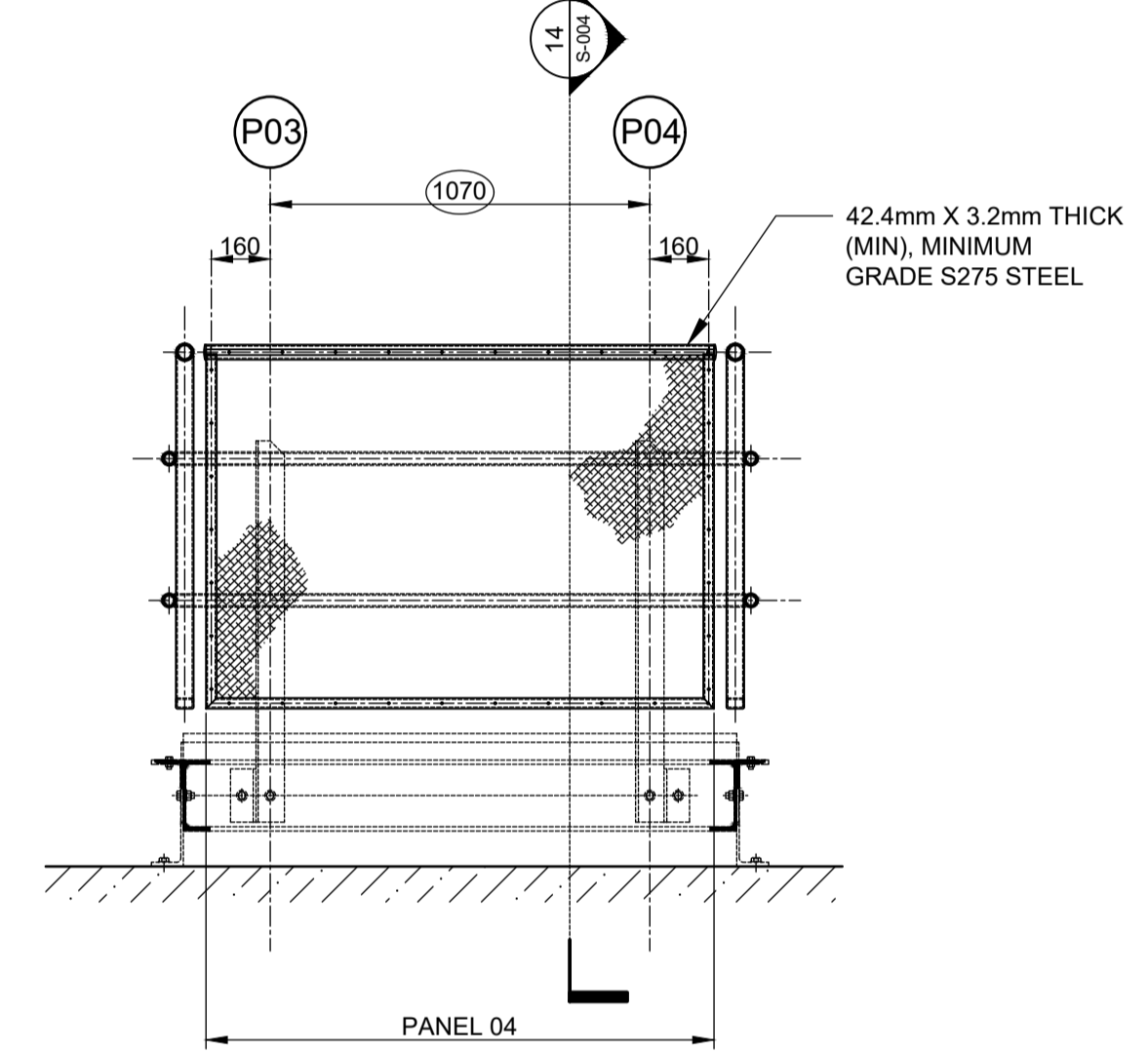

**ELEVATION - PLATFORM FRONT**  
(Scale 1:20)

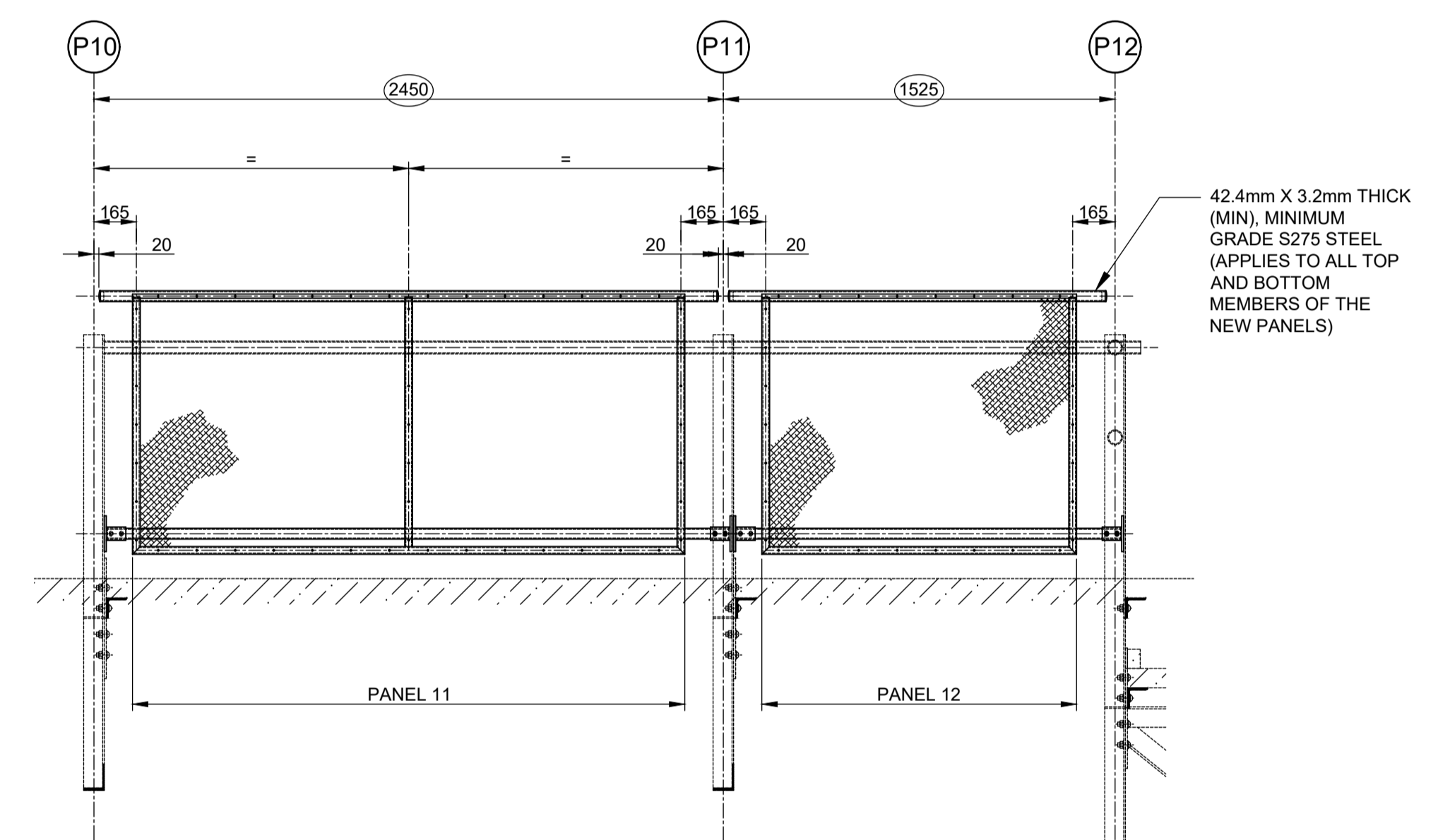

**ELEVATION ON PANELS**  
(Scale 1:20)

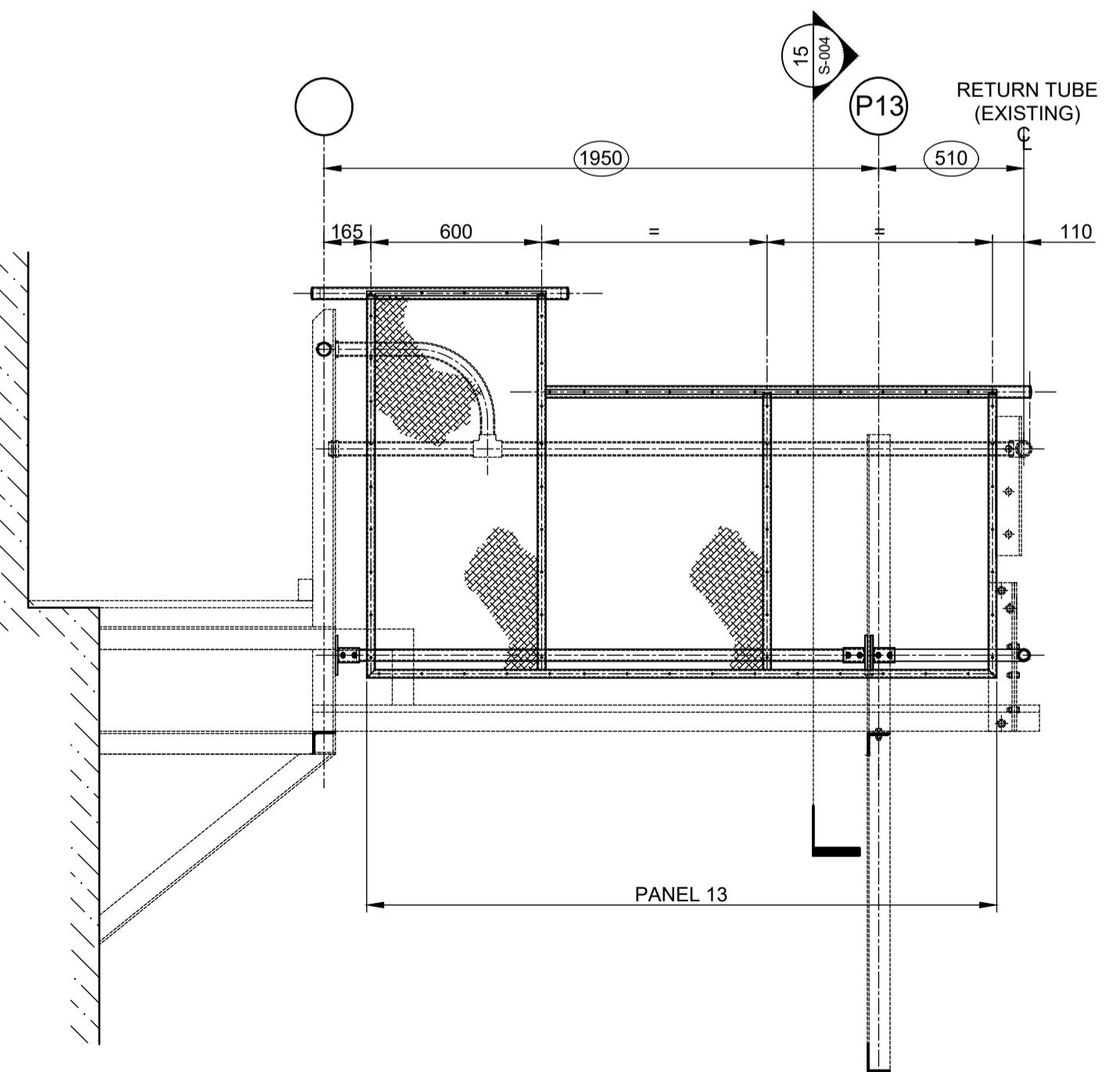

**ELEVATION ON END LANDING**  
(Scale 1:20)

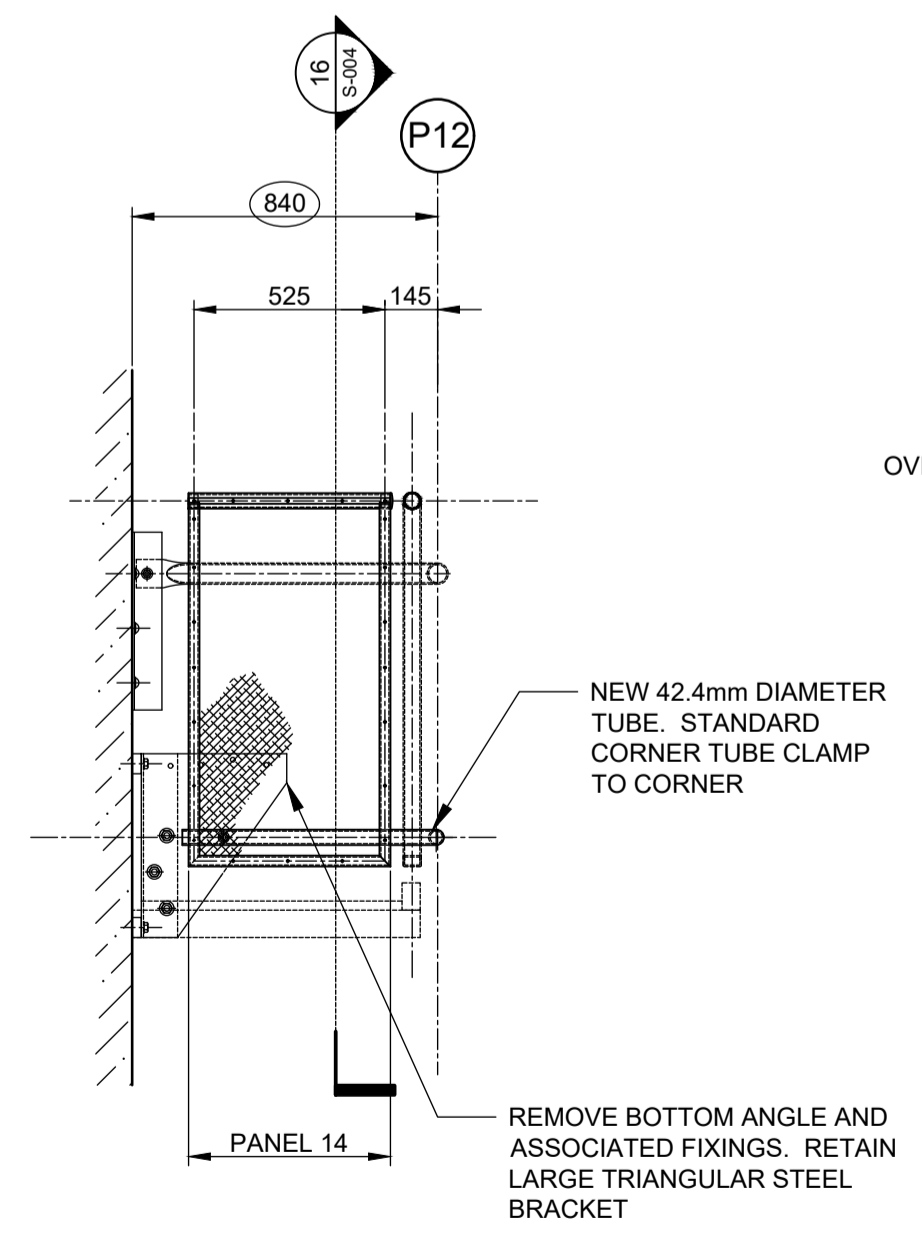

**ELEVATION ON END LANDING**  
(Scale 1:20)

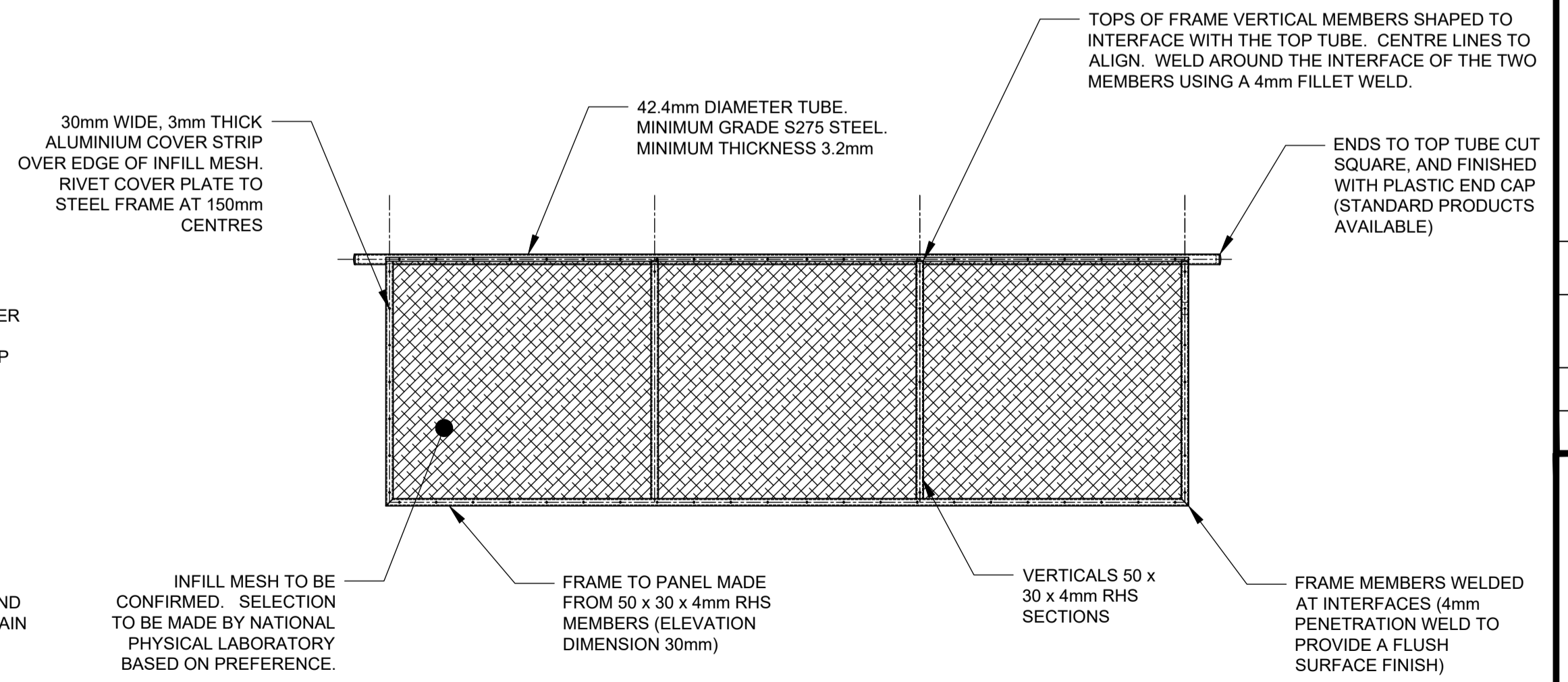

**ELEVATION ON TYPICAL INFILL PANEL**  
(Scale 1:20)

Rev	Date	Description	By	Chkd.
T1	04/05/20	ISSUED FOR TENDER		

Client:

Project:  
**BUILDING 47  
HANDRAIL RENEWAL**

Title:  
**ARRANGEMENT OF  
NEW INFILL PANELS**

Scale @ A1: 1:20  
Prepared by: MR  
Checked: MR  
Date: 4 MAY 2020  
Project Director: M Richards  
Drawing Status: TENDER

**nesta.**  
Consulting Engineers  
Garment Building  
9 Fishers Lane  
London  
W4 1RX  
tel: +44 (0) 7587 060616  
e-mail: Mark.Richards@nesta-ltd.com

Drawing No.: 20/010/S003 T1  
Revision: